

Honeywell

krom
schroder

| Industrial & Commercial Thermal

Solenoid valves for gas VGP

Technical Information · GB
3 Edition 10.11l

- Safety valves for gas
- Compact design saves space
- Low power consumption
- Simplified equipment saves costs
- EC type-tested and certified
- AGA approved
- Certified by Gosstandart pursuant to GOST-TR

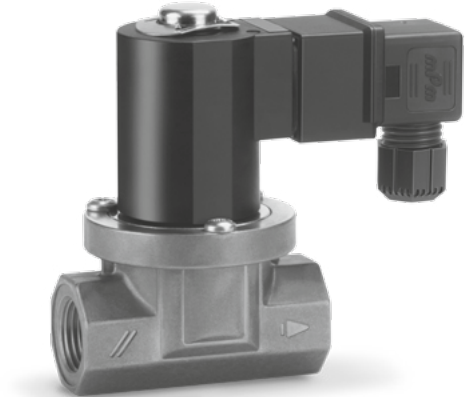

Contents

Solenoid valves for gas VGP	1
Contents	2
1 Application	3
1.1 Examples of application	3
2 Certification	4
3 Function	5
3.1 Animation	6
4 Flow rate	7
5 Selection	8
5.1 Type code	8
6 Project planning information	9
6.1 Installation	9
6.2 Wiring	9
7 Technical data	10
7.1 Dimensions	10
8 Maintenance cycles	11
Feedback	12
Contact	12

1 Application

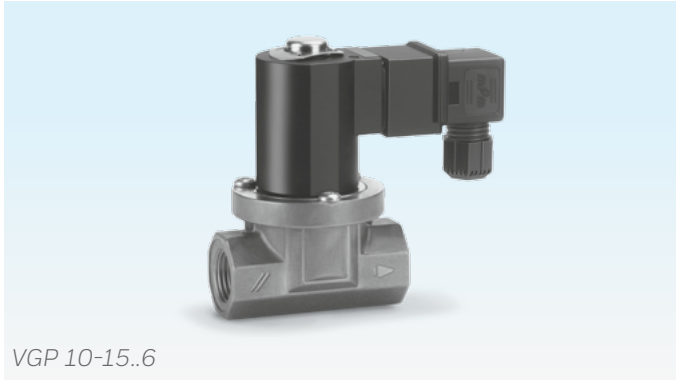

VGP 10-15..6

Gas solenoid valves VGP for safeguarding and controlling the air and gas supply to gas burners and gas appliances. For use in gas control and safety systems in industrial and commercial heat generation, such as the foodstuffs and ceramics industries.

1.1 Examples of application



Ceramics industry: roller hearth kiln



Ceramics industry: intermittent shuttle kiln

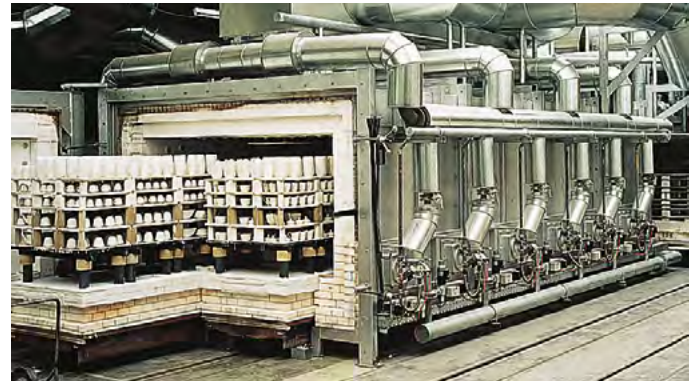

Ceramics industry: intermittent shuttle kiln

2 Certification

EC type-tested and certified



pursuant to

- Gas Appliances Directive (2009/142/EC) in conjunction with EN 161,

Meets the requirements of the

- Low Voltage Directive (2006/95/EC),
- EMC Directive (2004/108/EC).

AGA approved



Australian Gas Association, Approval No.: 5567

www.aga.asn.au/product_directory

Approval for Russia



Certified by Gosstandart pursuant to GOST-TR.

Approved by Rostekhnadzor (RTN).

Scan of the approval for Russia (RUS) – see www.docuthek.com → Elster Kromschroder → Products → O3 Valves and butterfly valves → Solenoid valves for gas VGP → Kind of document: Certificate → VGP B00071 (nat. Zertifikat Russland) (RUS)

3 Function

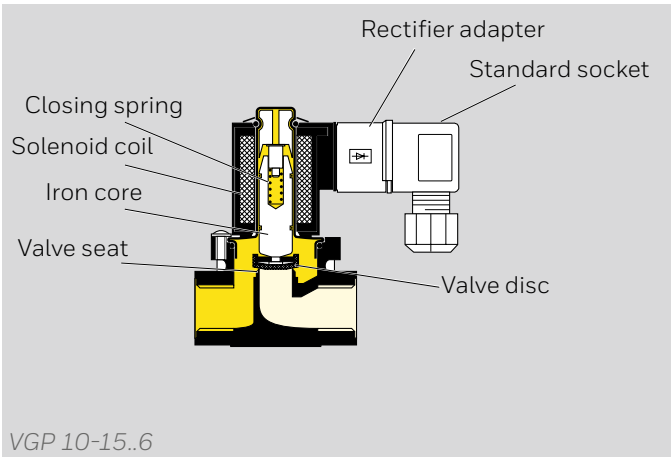

The gas solenoid valve VGP is closed when de-energized.

Opening: the applied AC voltage is rectified (the rectifier adapter must be installed for this) and generates a powerful magnetic field in the solenoid coil. The magnetic field attracts the iron core and lifts the valve disc from the valve seat, acting against the effective inlet pressure and the closing spring force. The gas solenoid valve VGP opens and the gas supply is released.

Closing: when the voltage is disconnected, the magnetic field collapses and within 1 s, the closing spring pushes the iron core with valve disc back onto the valve seat, assisted by the inlet pressure. The gas solenoid valve VGP closes and the gas supply is stopped.

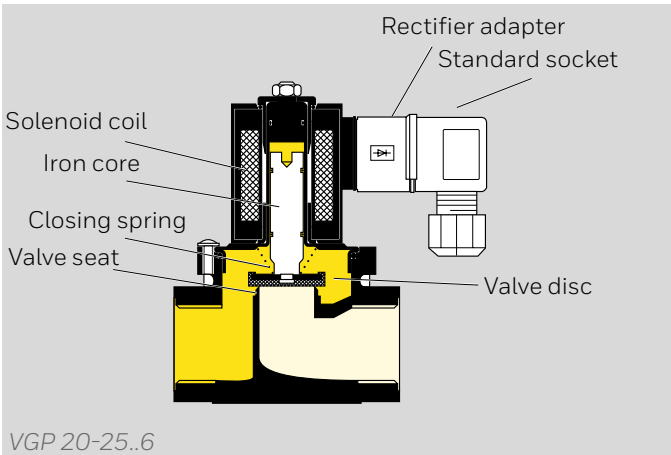

3.1 Animation

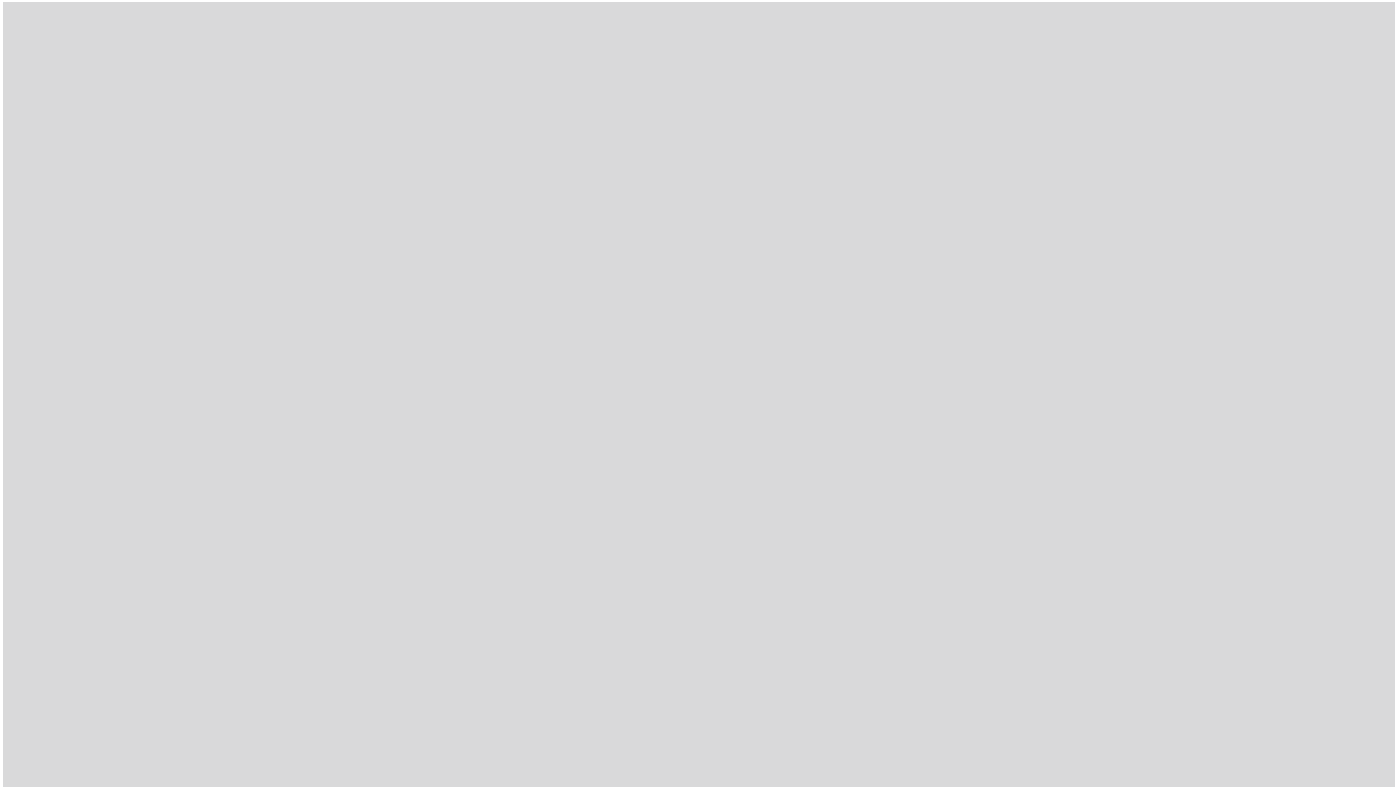

The interactive animation shows the function of the gas solenoid valve VGP.

Click on the picture. The animation can be controlled using the control bar at the bottom of the window (as on a DVD player).

To play the animation, you will need Adobe Reader 9 or a newer version. If you do not have Adobe Reader on your system, you can download it from the Internet.

If the animation does not start to play, you can download it from the document library (Docuthek) as an independent application.

4 Flow rate

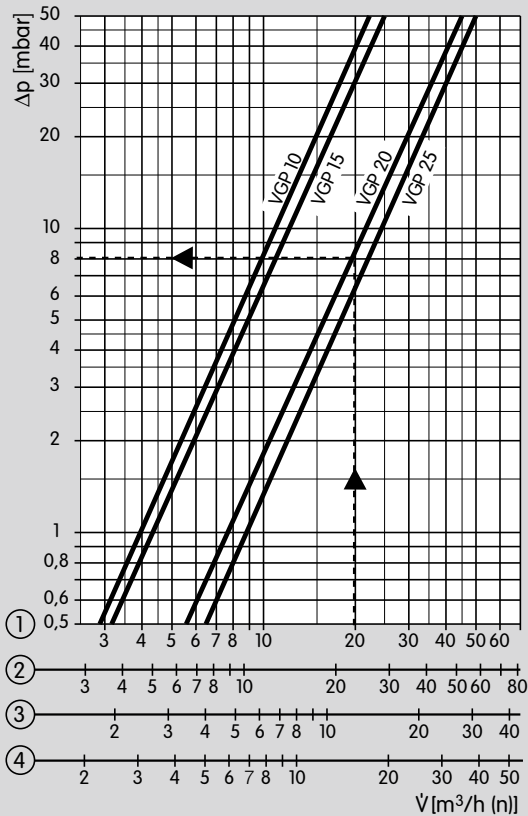

① = natural gas ($\rho = 0.80 \text{ kg/m}^3$)

② = town gas ($\rho = 0.64 \text{ kg/m}^3$)

③ = LPG ($\rho = 2.01 \text{ kg/m}^3$)

④ = air ($\rho = 1.29 \text{ kg/m}^3$)

Example:

gas type: natural gas,

flow rate = 20 m³/h,

Δp from diagram = 8 mbar,

solenoid valve VGP 20

5 Selection

Typ	R	01	02	W	Q	5	6
VGP 10	●	-	●	●	●	●	●
VGP 15	●	-	●	●	●	●	●
VGP 20	●	●	-	●	●	●	●
VGP 25	●	●	-	●	●	●	●

● = standard

Order example

VGP 20R01W6

5.1 Type code

Code	Description
VGP	Gas solenoid valve
10, 15, 20, 25	Nominal diameter
R	Rp internal thread
01	p _u max. 150 mbar
02	
Q	Mains voltage 120 V AC; 50/60 Hz
W	Mains voltage 230 V AC; 50/60 Hz
5	Connection via rectifier adapter without standard socket
6	

6 Project planning information

6.1 Installation



Installation position: black solenoid actuator in the vertical upright position or tilted up to the horizontal, not upside down.

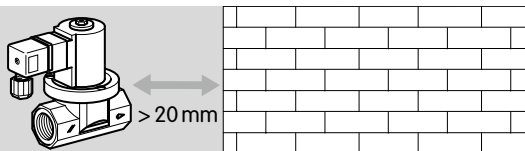

The gas solenoid valve VGP must not be in contact with masonry. Minimum clearance 20 mm.

Do not store or install the unit in the open air.

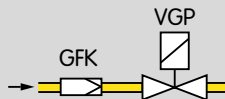

Sealing material and dirt, e.g. thread cuttings, must not be allowed to get into the valve housing.

Install a filter (GFK) upstream of every system.

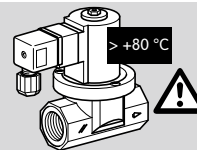

The solenoid body heats up during operation depending on ambient temperature and voltage.

6.2 Wiring

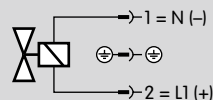

Wiring to EN 60204-1.

It is absolutely necessary to install a rectifier adapter (included in the delivery).

7 Technical data

Gas types: natural gas, town gas, LPG (gaseous), biologically produced methane (max. 0.1 %-by-vol. H₂S) or clean air; other gases on request. The gas must be dry in all temperature conditions and must not contain condensate.

Opening time: 0.5 s.

Closing time: < 1 s.

Ambient temperature: -20 to +60°C.

Storage temperature: -20 to +40°C.

Safety valve:

Class A Group 2 pursuant to EN 161,

Mains voltage:

230 V AC, +10/-15%, 50/60 Hz,

120 V AC, +10/-15%, 50/60 Hz.

Electrical connection:

plug with socket to EN 175301-803.

Power consumption:

Typ	120/230 V~ [W]
VGP 10	26
VGP 15	26
VGP 20	35
VGP 25	35

Enclosure: IP 54.

Duty cycle: 100%.

Power factor of the solenoid coil: $\cos \varphi = 1$.

Solenoid coil insulation: class F insulating material.

Switching frequency: any.

Valve housing: aluminium,
valve disc: Perbunan.

Internal thread: Rp to ISO 7-1.

7.1 Dimensions

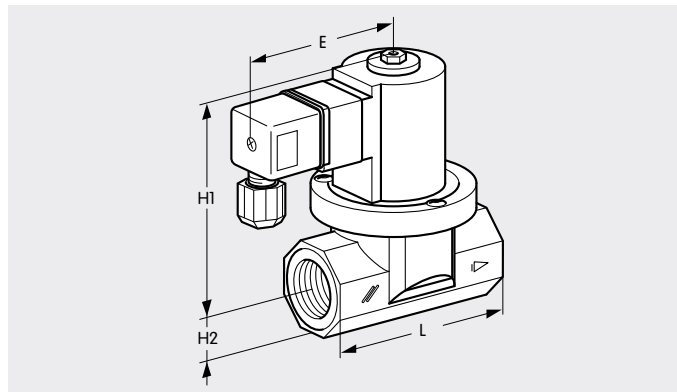

Data table [mm]

Type	Connection		Dimensions				p _u max. mbar	Weight g
	Rp	DN	L mm	H1 mm	H2 mm	E mm		
VGP 10	3/8	10	71	89	16	77	200	500
VGP 15	1/2	15	71	89	16	77	200	480
VGP 20	3/4	20	91	105	23	78	150	800
VGP 25	1	25	91	105	23	78	150	780

8 Maintenance cycles

At least once a year, twice a year in the case of biologically produced methane.

Feedback

Finally, we are offering you the opportunity to assess this “Technical Information (TI)” and to give us your opinion, so that we can improve our documents further and suit them to your needs.

Clarity

- Found information quickly
- Searched for a long time
- Didn't find information
- What is missing?
- No answer

Comprehension

- Coherent
- Too complicated
- No answer

Scope

- Too little
- Sufficient
- Too wide
- No answer



Use

- To get to know the product
- To choose a product
- Planning
- To look for information

Navigation

- I can find my way around
- I got “lost”
- No answer

My scope of functions

- Technical department
- Sales
- No answer

Remarks

Contact

Elster GmbH
Postfach 2809 · 49018 Osnabrück
Strothweg 1 · 49504 Lotte (Büren)
Germany

Tel +49 541 1214-0
Fax +49 541 1214-370
info@kromschroeder.com
www.kromschroeder.com

The current addresses of our international agents are available on the Internet:
www.kromschroeder.de/Weltweit.20.0.html?&L=1

We reserve the right to make technical modifications in the interests of progress.
Copyright © 2016 Elster GmbH
All rights reserved.

Honeywell

**krom
schroeder**