



INSTRUCTION MANUAL - English

Safety accessory for minimum level, series 210 + 800.

Code: **210-2XY-0Z Electronic self testing conductivity level switch**
800-000-50W Safety probe

Thank you for purchasing 210/800 series level switch. Before using the device, please read carefully this manual, and keep it in a safe place, for future use.

1 - Description

The electronic self testing conductivity level switch series **210** and the safety probe series **800**, are, as a whole, a limiting device safety accessory, in IV category for industrial boilers and steam generators.

They are compliant to the following European Directives:

Low Voltage Directive	2006/95/EC
EMC Directive	2004/108/EC
PED Directive	97/23/CE.

Applied norms: EN 12953. 9

Thanks to the particular mechanical building of the probe and to the use of a specific electronic circuit, the device can measure with safety the water presence inside a boiler. The measure is conductive.

Two independent alarm contacts signal:

- water lack, below the established level
- isolation loss inside the probe;
- failure situation inside the device (self-testing);
- wiring break between the probe and the device

The reset of the regulator is automatic; if manual reset is required, this must be carried out by external circuitry.

With respect to EN 12953-6 standard (TRD 604), regarding our security accessories, we affirm that they meet the regulation in items relative to minimum water level limiter.

2 - Technical characteristics of electronic self testing conductivity water level switch, series 210

- power supply with transformer compliant to EN 60742, according to order code:

Z=1	→	24V AC	+10% -15%
Z=2	→	110 V AC	+10% -15%
Z=3	→	230 V AC	+10% -15%
Z=4	→	24 V DC	+20% -15% (special optional accessory is required)

- Overvoltage category: II
- Pollution degree = 2
- frequency: 47/60 Hz
- protection grade: IP10
- absorption: 8 VA
- temperature environment: 0°C ÷ 55 °C
- electronic working, controlled by digital signal processor (dsp)
- conductivity double measure circuit, with compensation electrode
- during internal tests (self-testing procedures) for 1" every 60", the water level control is not performed



- output: 2 exchange independent relays contacts, 230V - 2.5A - AC1 (resistive load), 10 million operations unloaded; 260000 operations loaded
- positive safety, burner break circuit, for 210
- conductivity:

Y=0	→	> 100 μS/cm
Y=1	→	10 ÷ 500 μS/cm
Y=2	→	0.5 ÷ 20 μS/cm

- maximum voltage on the electrode = 1.0 V_{RMS} AC at 150 Hz, with no DC component
- mechanical dimension (mm):

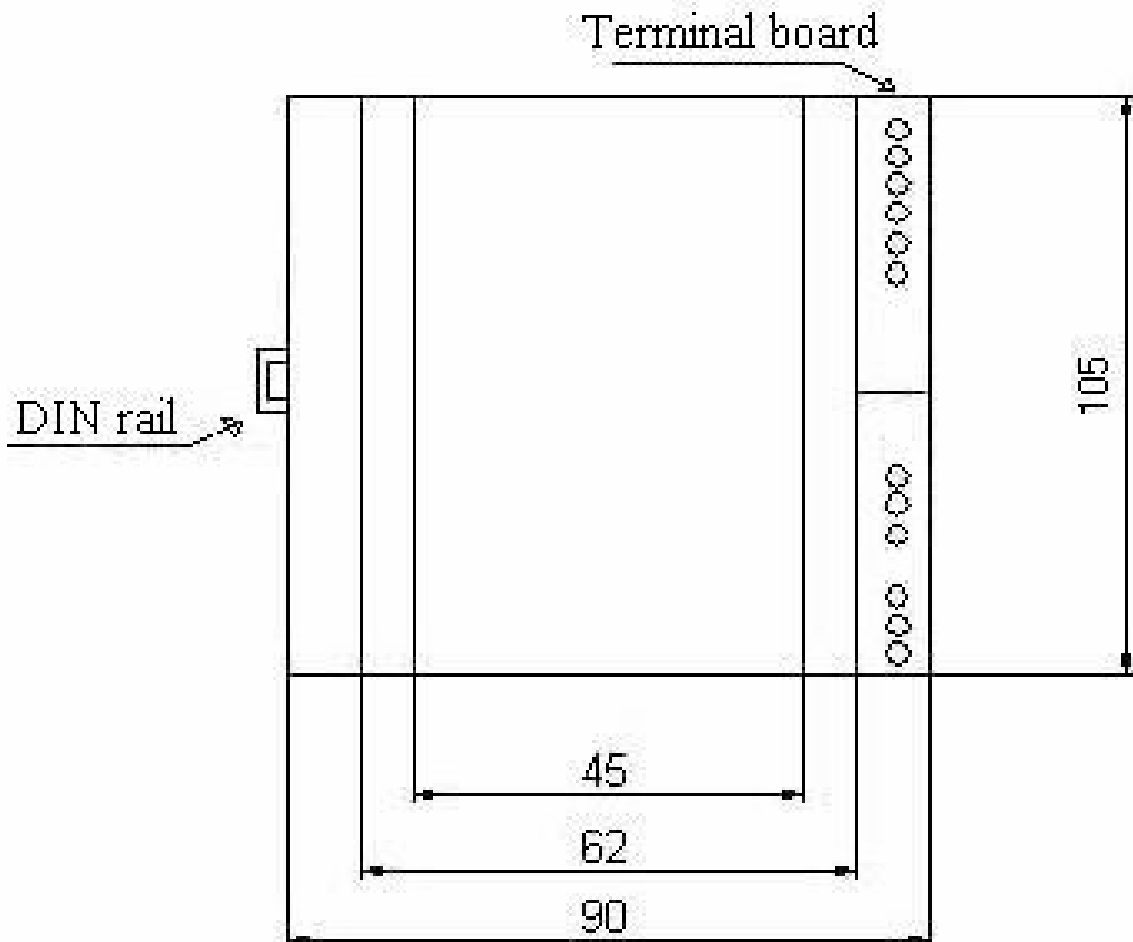
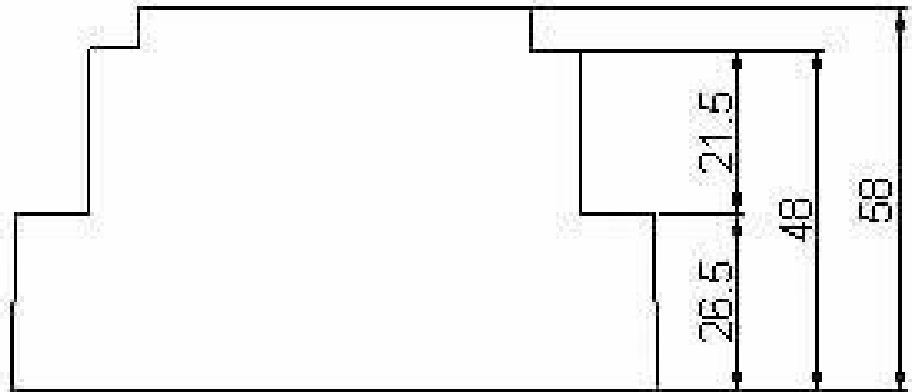



3- Technical characteristics of the probe

- connection to the process; it depends on the order code:

W=0	→	1/2" gas
W=1	→	3/4" gas

- PS = 32 bar (on the electrode)
- TS = 239 °C (on the electrode)
- electric connection: DIN 43650 male IP65
 - body in stainless steel in agreement with prEN 12953-9 item 4.2.1, with PTFE isolation
- mechanical dimension (mm):

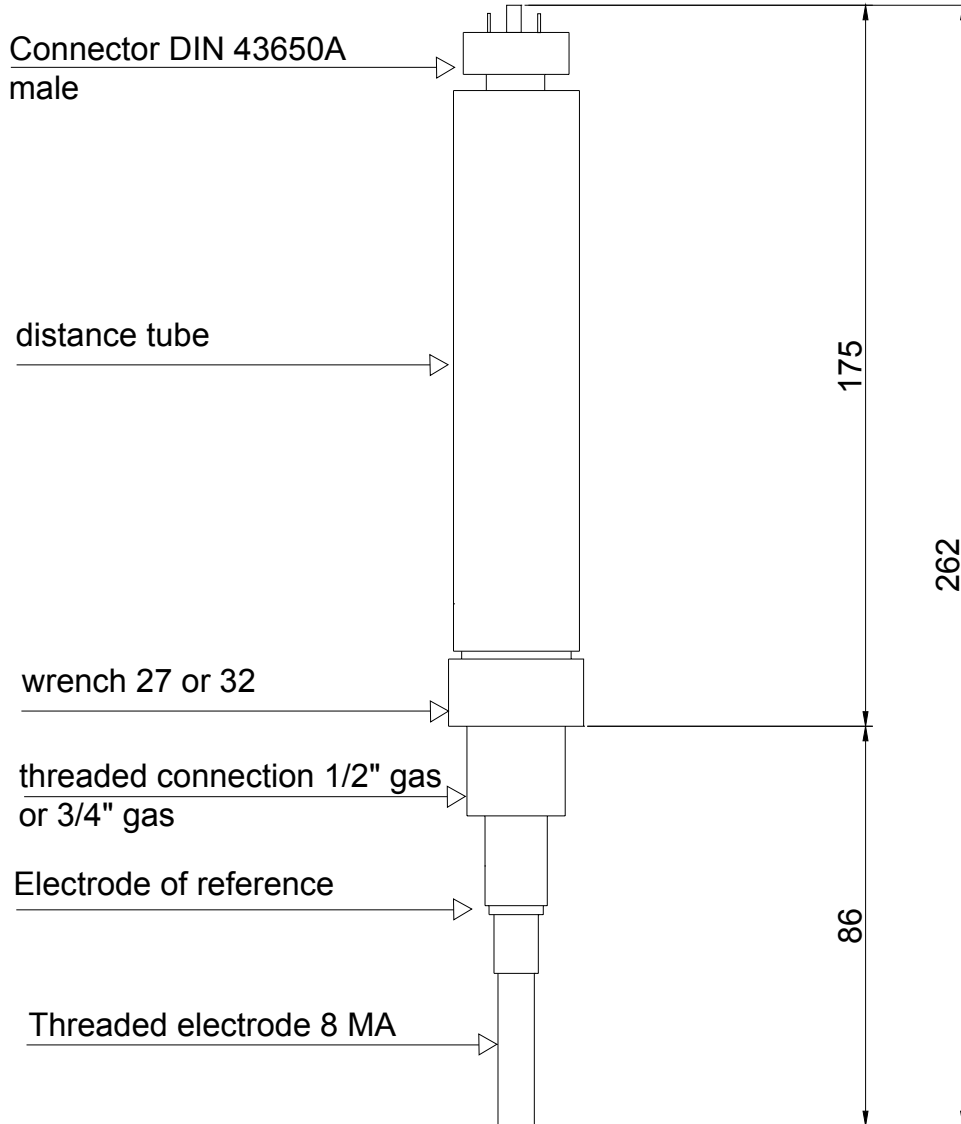



4 – General Safety informations

Safe operations on the product depend on a correct installation, use and maintenance by qualified staff, in accord with the operational instructions.

For qualified staff we mean people that have:

- knowledge on electrical engineering
- knowledge on electric safety regulations
- knowledge of accidents prevention

It is important to follow general instructions, safety installation procedures, thermal and electric safety regulations, to properly use all the tools and safety equipments.

The product has been designed and produced to withstand the conditions encountered during normal use.

The use of the product for any other purpose, or failing its proper installation, not following the instructions, can cause damage to the product, can invalidate its marking CE, and can cause serious injuries or fatality, to people, to things and to environment.

The level probe and the regulator are only a part of the safety chain.

To complete the safety chain, additional devices are required, as wirings, relays, bells, lamps, actuation devices.

The chain has to be designed and built to be fail-safe.

In case of fire in the environment, or seismic events or adverse atmospheric events (wind), the correct working of the safety accessory is not guaranteed any more.

In these cases, the power supply must be immediately removed from the safety accessory, and the probe, the regulator and the cable between them, must be checked by qualified staff.

Only after having verified that the accessory is not damaged, it is possible to give power supply again.

4.1 Probe

All the operations on the probe must always be done exclusively by qualified staff.

The operations on the probe must always be done with boiler not under pressure, vented to atmosphere and cold.

Remember that a boiler remains at high temperature also a long time after having turned off the pressure.

Contact, if possible, the builder of the boiler, to get information on the water alarm level.

Consider carefully, that in some cases, the water level in the boiler can be different from what you can see outside from the external indicator.

The electrode has to be far from the protection tube (if exist), or from the wall of the boiler, for at least 14 mm.

Do not install the probe in the open air without a suitable protection against the atmospheric agents.

The vent and drain hole has to be free and clear, and not covered.

4.2 Level regulator

Always entrust all the operations on the regulator exclusively to qualified staff.

The operations on the regulator must be always performed with the power supply off, because, if power supply is connected, dangerous voltages are present inside the regulator.

Before carrying out whichever operation or test on the safety accessory, it is necessary to discharge electrostatically to avoiding to damage the equipment.

The regulator has to be protected, with respect the power supply, by a suitable system according to the construction norms of the electric cabinet and plant, against risk of short circuits or overcurrent, to allow easy maintenance, service and repair.



5 - Installation

5.1 - Mechanical assembly of the probe

The probe series **800** must be vertically assembled in the boiler.

The high for low-level alarm is at the lower end of the electrode, which therefore must be cut to the necessary length.

For cutting the electrode, please follow the following procedure.

1. The lower end of the probe is threaded, and it has a hole; it must be assembled to the electrode using the thread, the retaining pin and the lock-nut.
2. Screw the lock-nut completely onto the probe, but do not tighten it in this phase.
3. Using a 6mm spanner on the probe flats, prevent the probe rotation.



WARNING: if the threaded end of the probe is allowed to rotate in the body of the probe, a damage of the internal wiring could take place.

4. Screw the electrode onto the probe until the hole of the probe lines up with the bottom end of the slot in the electrode (see the following image).

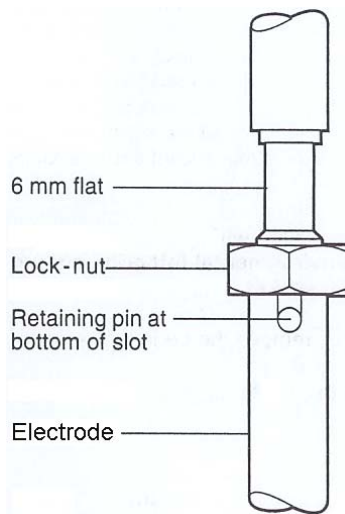

5. Holding the assembly up, insert the retaining pin until its protrusions from both sides of the electrode are symmetric.
6. Tighten the lock-nut onto the electrode (with torque $4 \div 7 \text{ Nm}$); these operations prevent the unscrewing and loosening of electrode.
7. Be sure that the water level in the boiler is at the minimum height which is required for safety.
8. Mark a line for all the length of the electrode using a felt-tip pen with water soluble ink.
9. Insert the probe with the assembled electrode, in the boiler: the positioning must be made so that foams or internal turbulence in the boiler do not alter the functionality of the probe.
10. Hand tighten the probe.
11. Remove the probe and mark the point at which the ink is dissolved by water.
12. Cut the electrode to this length using a fine hacksaw.
13. Deburr the end of the electrode.

The probe with electrode can now be assembled permanently at the boiler.

Interpose the usual copper gaskets.

The electric contact between the thread of the probe and the body boiler must be sure; bad contact can cause the malfunction of the regulator.

For correct working, the probe series 800 must not be necessarily assembled inside a pipe; however to reduce the effects of the undulations of level, of foam or of turbulence, a pipe can be suitably used.



The pipe must present some holes in this body, to allow the free circulation of water and cleanliness, to prevent the formation of deposits; these holes must have a diameter larger than 20 mm and smaller than 1/3 of the internal diameter of the pipe itself.

Holes will be positioned in the low part and in the high part of the pipe itself.

In any case, the minimum distance between the measure electrode and the ground, or other parts internal to the boiler and the pipe, must be higher than 14 mm.

One probe series 800 only must be positioned inside the pipe.

Follow the indications of the following drawing.

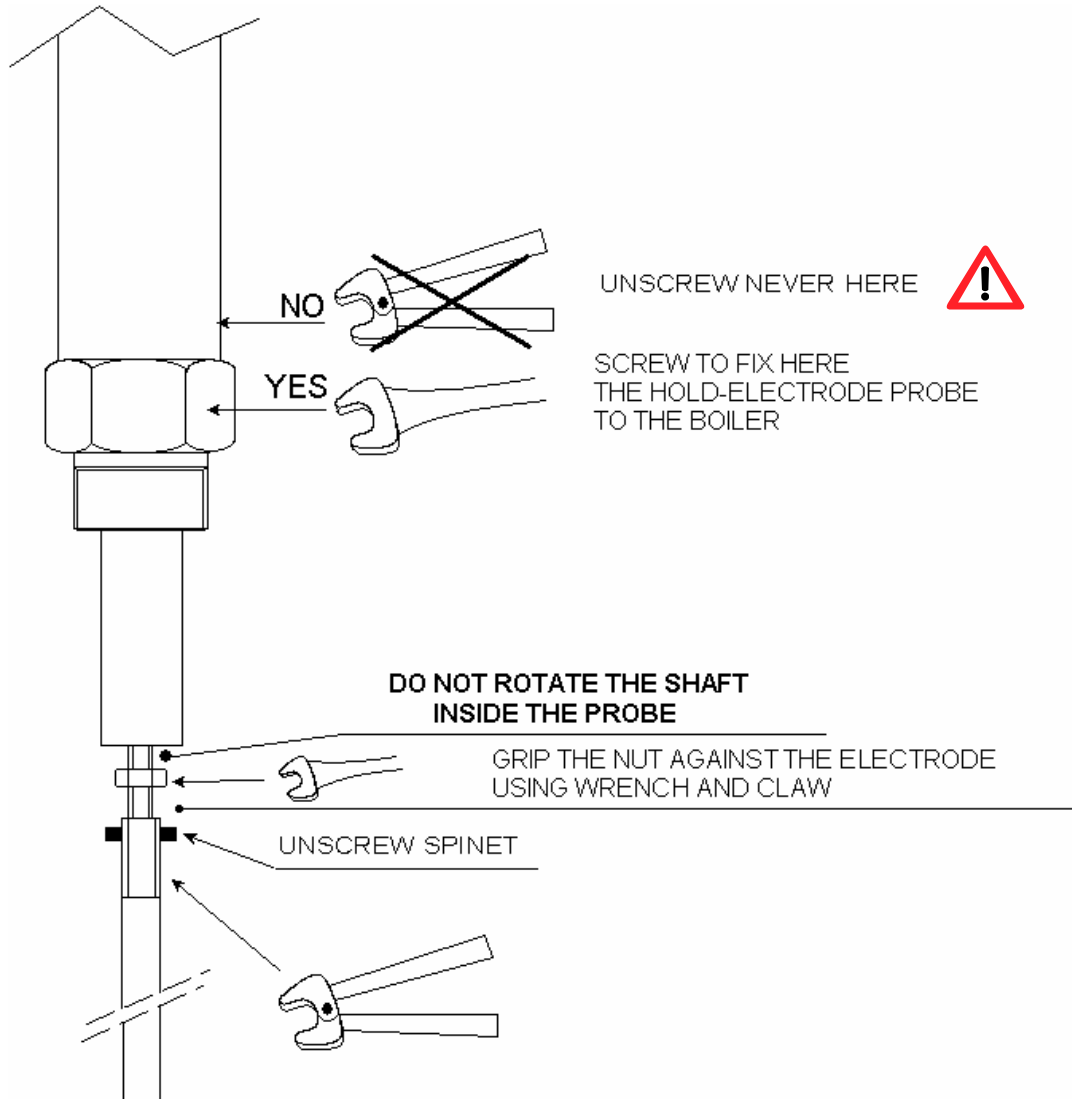

5.2 - level regulator installation

The 210 series regulator must be always inserted in a suitable industrial electric cabinet, with protection adequate to the environment, or in a fireproof enclosure.

The enclosure must have IP4X protection grade or superior.

The regulator must be placed inside the electric cabinet, using the suitable DIN rail hook (v. §2).

In the case of use of more than one regulator in the same electric cabinet, allow at least 15 mm spacing between them, for air circulation.



WARNING: danger! during the operation, the terminal block of the regulator is at dangerous voltage: this presents the danger of electric shock.. The operations on the regulator must always be done without the power supply voltage applied to the unit; see also §4.



For the electric wiring, refer to the following diagram:

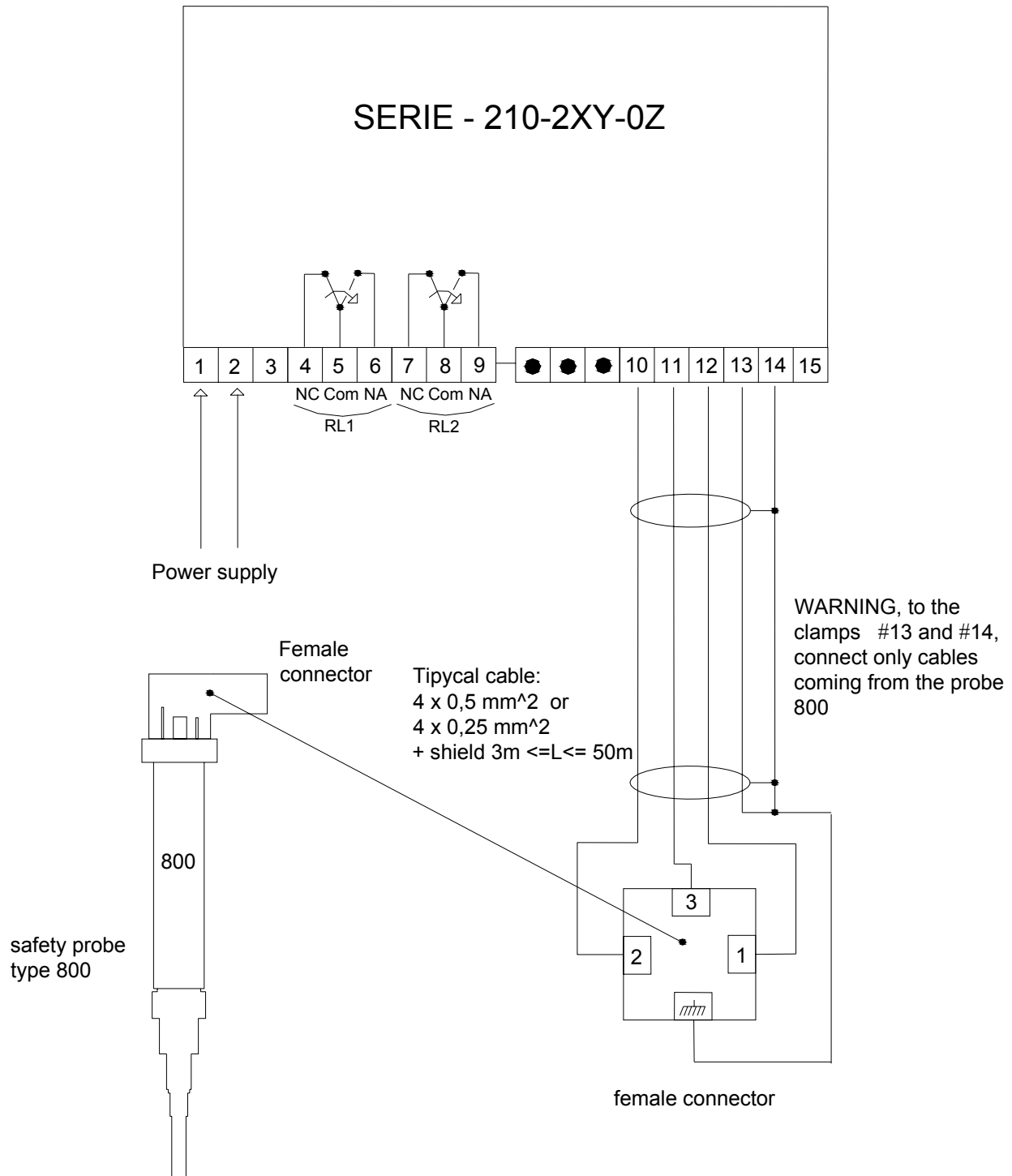

5.3 - Electric power supply (Terminal board 1-2)

- For X=0 and X=1 in the order code:

Before powering the device, verifying that the power supply Voltage corresponds to what is indicated on the identification label, within -15% e +10%, with AC power supply.

Verify that powering the regulator, the front green led labelled "Power" is turned ON.



- Only for X=1 in the order code:

Remove the frontal transparent protection of the regulator (where there is the label), using gently a flat blade small screwdriver, in the center of each side.

So, it will be possible to access the push button P1 and the switch S1.

Be sure that the switch S1 is in the Normal position (=N).

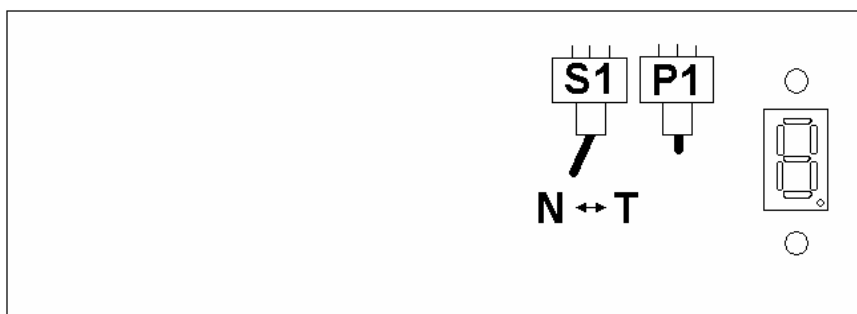

S1: selector for the test of the reference electrode

- position T = test
- position N = normal

P1: push button for the test of the measure electrode

- it is normally disabled

With a light pressure, put in its original position the frontal transparent protection, so that the label is in the original position, seeing correctly the 2 leds and the display.

5.4 - Wiring between probe and regulator (Terminal board 10-11-12-13-14)

For the wiring between the probe and the regulator, use a 4 x 0.25 mm² or 4 x 0.50 mm² screened cable; the cable has to be suitable to the temperature of the environment in which is used, particularly near the boiler. The maximum length of the cable is 50 m.

As shown in the drawing above, wire the cable end with a DIN female connector, supplied with the probe, to be able then to make the wiring with the head of the probe in a fast and safe way.

The cable screen is a functional ground, not a protective earth.

Connect the cable screen as in the scheme above (§5.2).

Do not connect to the clamps #13 and #14 of the regulator protective earth wiring: this could create undesired earth loops, which may reduce the performance of the regulator, and eventually damage it.

5.5 - User's wiring (Terminal board 4-5-6 and 7-8-9)

The regulator makes available in output 2 independent contacts in exchange, which can be used to control the boiler burner and to give alarm.

The contacts are closed in case of not alarm; open in case of alarm (positive safety).

A recommended diagram, is on the § 6.

In the case of switching inductive loads, contact commutation produces voltage spikes that can influence the operation of the measurement and control systems.

The user will have to use appropriate surge arresters on the contacts, in function of the load which will apply to the contacts themselves, in agreement with prEN 12953-9 item 4.4.3.4.



6 - Working

The regulator continuously measures two different electric resistances: the first between the measure electrode and the ground of the boiler; the second between the reference electrode and the ground of the boiler.

Analysing the value of these 2 resistances, the device is able to determine if there is water in contact of the measure electrode and if the probe has an isolation loss.

Every 60 seconds the device performs internal diagnostic tests to verify its functionality in the ohmic measurements on the measure electrode and on the reference electrode; and to verify the wiring cable integrity.

The analysis of all measures leads to the determination of the state of the system: if it is in one of the conditions of alarm recognized, the device brings him in the sure condition of alarm.

6.1 - For both the versions of $X=0$ and $X=1$ in the order code:

Being the system a positive safety device, in condition of not alarm the 2 internal relays are ON, the front red led labelled "Safe" is ON and the 8 segments display shows '0'.

In case of alarm, the relays open, the front red led goes OFF, the display shows a different code from '0' corresponding to a situation of alarm and the relays contacts in exchange can be used from an outside logic.

List of alarm codes with the corresponding situation for version 210:

Code	Situation
0	no alarm (normal situation); water presence
1	no water
2	interrupted cable or not communication with probe
3	anomalous operation
4	no water
5	no water
6	interrupted cable or no communication with probe
7	anomalous operation
8	water presence on the reference electrode
A	test of R_r in parallel to 100 ks ohm not in the limits
b	test of inside resistance to 1 M ohm not in the limits
C	test of the inside resistance to 100 ohms not in the limits
F	interrupted cable or not communication with probe

6.2 - Possible solutions to failure

Alarm codes 1, 4, 5	<p>verify that the level of the water is indeed below the minimum required.</p> <p>If the level is above, and the situation of alarm remains, verify that the conductivity of the water in the boiler is in the conductivity range, of the used regulator (see its label).</p> <p>If it is out of range, it is necessary to replace the regulator with a proper one, with the correct conductivity of the used water.</p> <p>If conductivity is in the range, verify the connection between the regulator and the probe, the integrity of the probe, and of the electrode.</p>
Alarm codes 2, 6, F	<p>verify the connection between the regulator and the probe; if it has been performed as from scheme §5.2, and the situation of alarm remains, it means that there is an break in the connection.</p> <p>For $X=1$, verify that the selector S1 is in position N; otherwise move it from the position T to the position N.</p>
Alarm codes 3, 7	<p>possible failure inside the regulator; if the alarm remains, it is necessary to</p>



	replace the regulator.
Alarm code A	possible failure inside the regulator (related to the self-testing) or in the connection's cable with the probe. Verify the connection with the probe. If the cable is not damaged, and the alarm remains for more than 60", it is necessary to replace the regulator.
Alarm codes b, C	possible failure inside the regulator, related to the self-testing; if it remains for more than 60", it is necessary to replace the regulator;
Alarm code 8	Verify that the water's level in the boiler doesn't reach indeed the level to the reference electrode (v. picture §3). If the level is below, verify that the conductivity of the water in the boiler is in the range of conductivity of the used regulator (see its label); if it is out of range, it is necessary to replace the regulator with a proper one with the correct conductivity of the used water. If conductivity is in the range, it is necessary to remove the probe from the boiler (following the instructions at §4), and verify that there aren't deposit or dirt on the probe. If there are not deposit or dirt on the probe, an infiltration could have taken place in the body of the probe; in this case it is necessary to replace the probe.

If, after the suggested inspection, the alarm condition remains, or different situations arise, it will be necessary to replace the whole safety accessory (regulator + probe), and contact our technical service.

6.3 - Only for version with X=1 in the order code:

It is possible to verify manually some important functionalities of the regulator.

These tests must be performed only by qualified technical staff (v. §4).



Warning: consider carefully that during these manual tests, an alarm is intentionally produced and the boiler will stop; take all the necessary actions so that this doesn't involve risks for the operation of the boiler, for the people, or for the environment.

To perform these tests, it is necessary to remove the frontal transparent protection of the regulator (where there is the label), using gently a flat blade small screwdriver, in the center of each side.

So, it will be possible to access the push button P1 and the switch S1.

With the level of the water above the safety minimum, and therefore with the regulator in safety condition, pressing for at least 5" seconds the pushbutton P1, one can simulate a situation of lack of connection of the measuring electrode; if this is correctly recognized, the specific alarm coded as '2' is given, with commutation of the relay of alarm.

Releasing the button P1, the regulator must return in state of not alarm, within 3 seconds.

If there is a lockout circuit with manual reset, the operator will have to restart the boiler.

Switching the switch S1 in Test position (=T), simulates the lack of connection of the reference electrode: within 60" the regulator must recognize this situation coded as 'F'.

Even in this case, if there is a lockout circuit with manual reset, the operator will have to restart the boiler.

At the end of the test, the switch S1 must be switched in Normal position (=N).

Under a light pressure, put the frontal transparent protection in its original position, so that the label is in the original position, and you can correctly see the 2 leds and the display.

If at least one of the 2 manual tests isn't carried out successfully, as described above, it means that the regulator doesn't work correctly, and therefore must be replaced and repaired, according to the operational and installation procedures.

An example typical of work for the series 210 is the following:

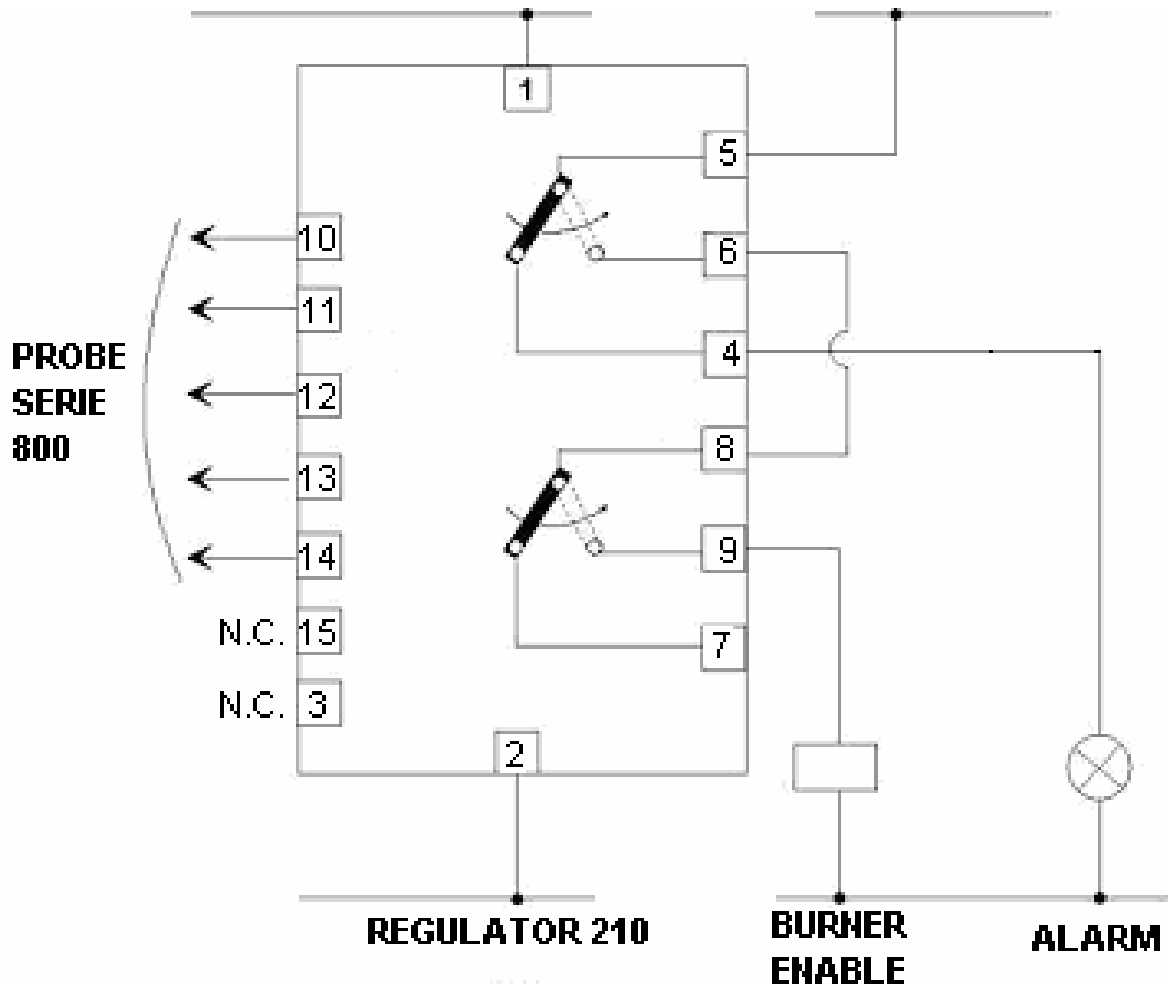

7 - Maintenance

The regulator does not require particular maintenance or service.

The probe has to be cleaned and inspected once a year.

For aggressive waters, verify periodically the measure electrode; clean it with an abrasive paper (operate on the probe always with cold boiler and not under pressure).

Test occasionally the functionality of the equipment, simulating manually any possible alarm condition and verifying the correct answer of the equipment, in agreement with prEN 12953-9 item 5.6.3.

After the maintenance, assemble everything following the instructions from the point 5 of the present instructions manual.

8 - Divestment

Entrust this operation to qualified staff.

The unusable equipments must be swallowed with a procedure which guarantees the safety.



9 – Accessories

Provided accessories

- connector DIN 43650A female cod. 999-027-00, as end part of the wiring cable between the probe and the regulator
- copper gasket

Optional on request:

- 10 mm diameter electrode, with 500 mm length (cod. 999-800-05)
- 10 mm diameter electrode, with 1000 mm length (cod. 999-800-10)